

Energy Consumption in IP Networks

Rodney S. Tucker, Jayant Baliga, Robert Ayre, Kerry Hinton, Wayne V. Sorin

ARC Special Research Centre for
Ultra-Broadband Information Networks (CUBIN)
University of Melbourne

r.tucker@ee.unimelb.edu.au

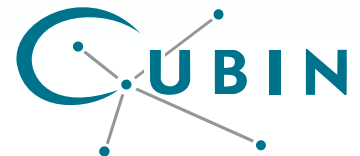

Energy Consumption of the Network

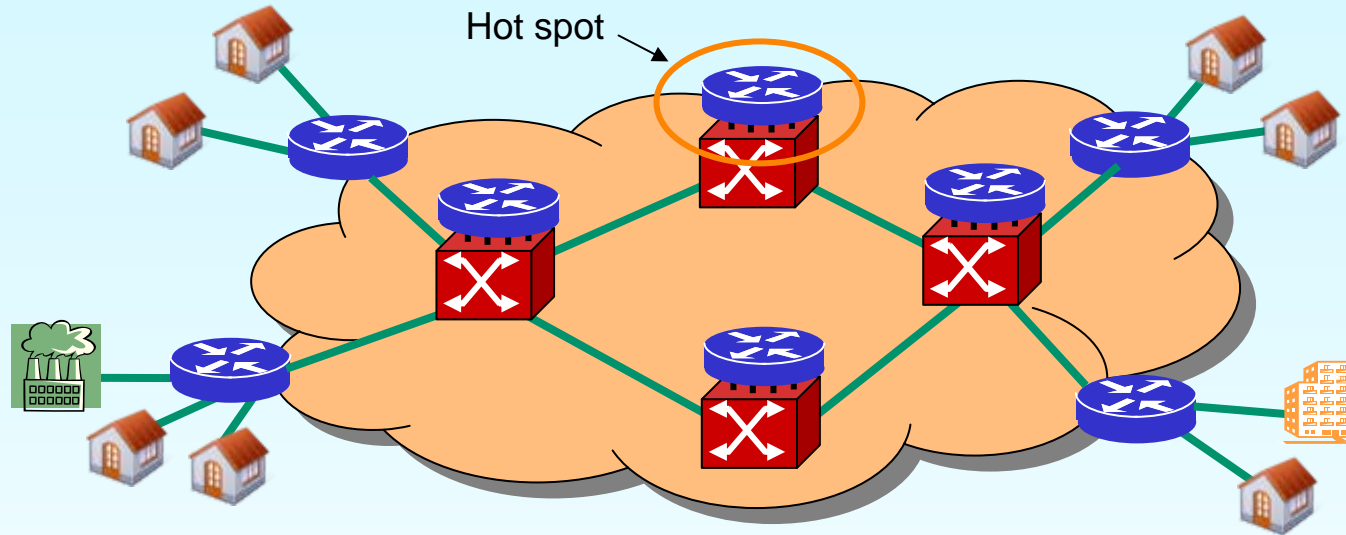

Why should we be interested in energy?

- OPEX
- Greenhouse Impact
- Managing “Hot Spots”
 - Getting the energy in
 - Getting the heat out
- Energy-limited capacity bottlenecks
- Enabling energy efficiencies in other sectors

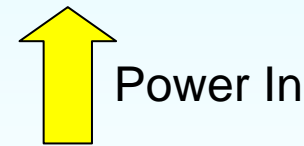

Where are We Heading ?

- 
- More users
 - More data-intensive applications, e.g. video
 - More often and for longer periods
 - Increasing demand → operators provide faster access and increased core capacity
 - New applications enabled by faster access



Energy Consumption Grows

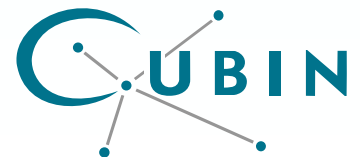

Summary

- Modeling energy consumption of the Internet
 - Core, metro, and access networks
- Where does the energy go?
- Will (can) optical switching technologies help to reduce energy consumption?
- A Word of Warning



What is the Carbon Footprint of Telecoms?

Global Telecoms Footprint (devices & infrastructure)

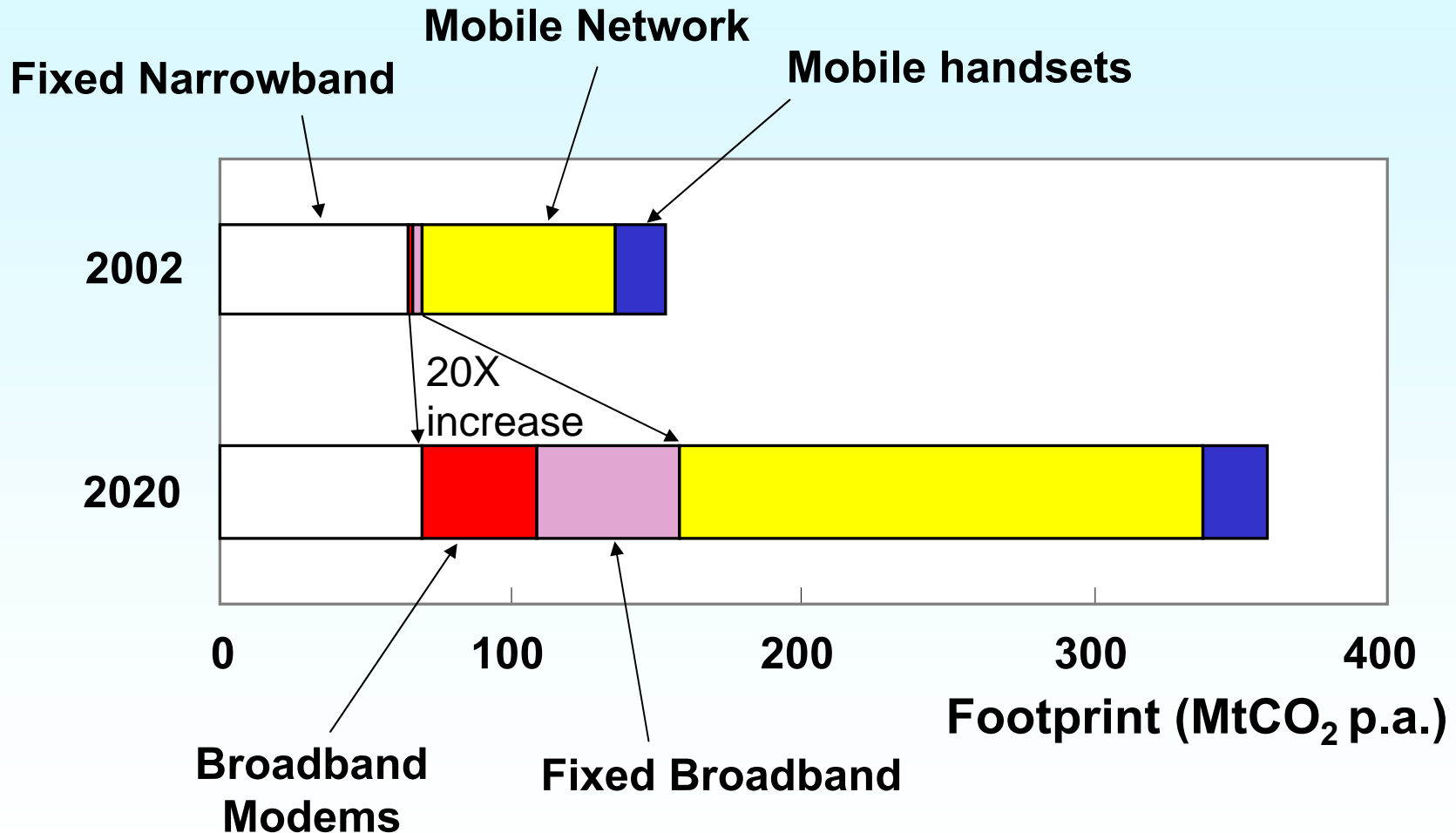

Adapted from "SMART 2020: Enabling the low carbon economy in the information age," GeSI, 2008 www.gesi.org



Where does the Energy Go?

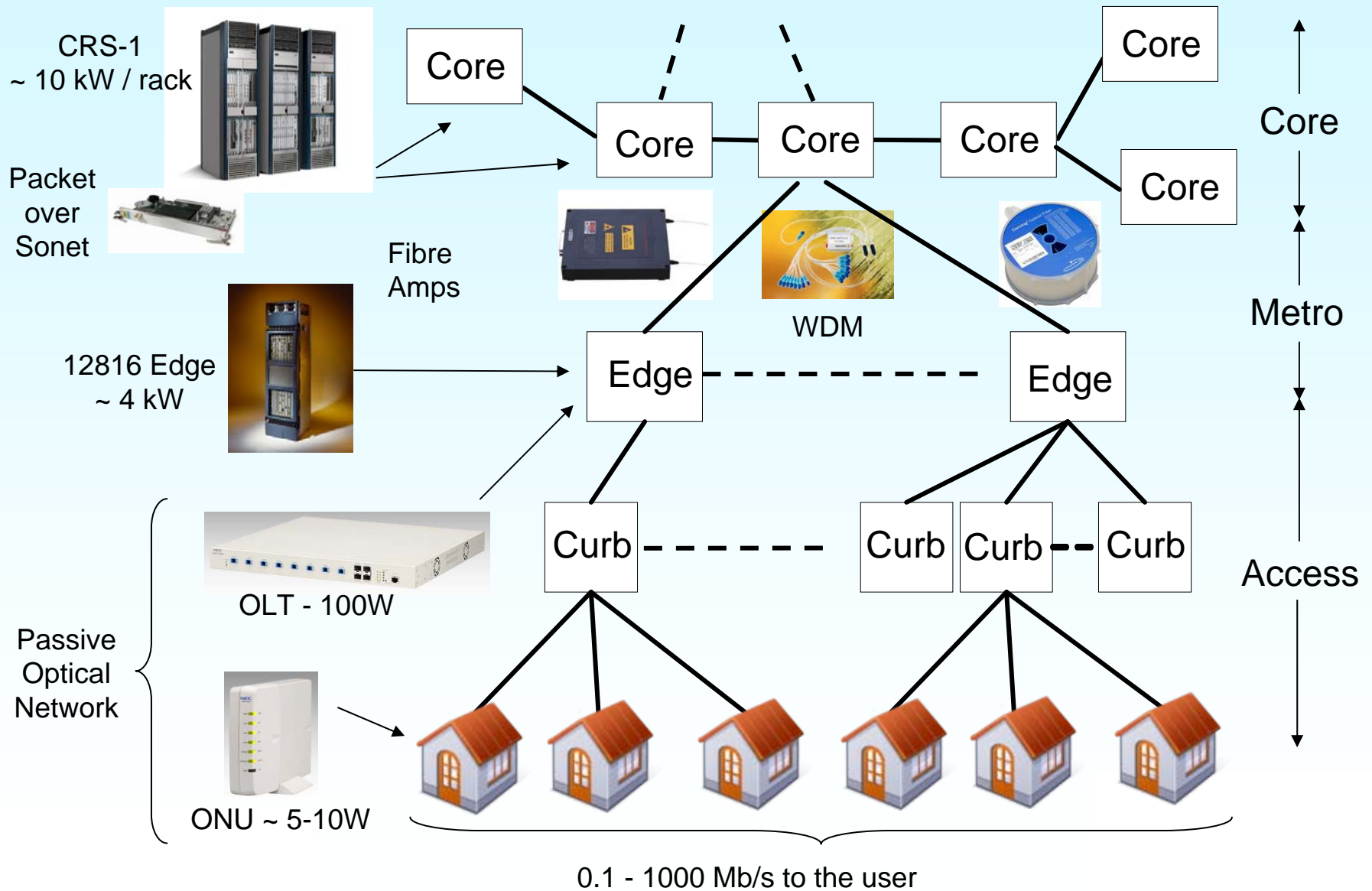

Number of Hops in the Internet

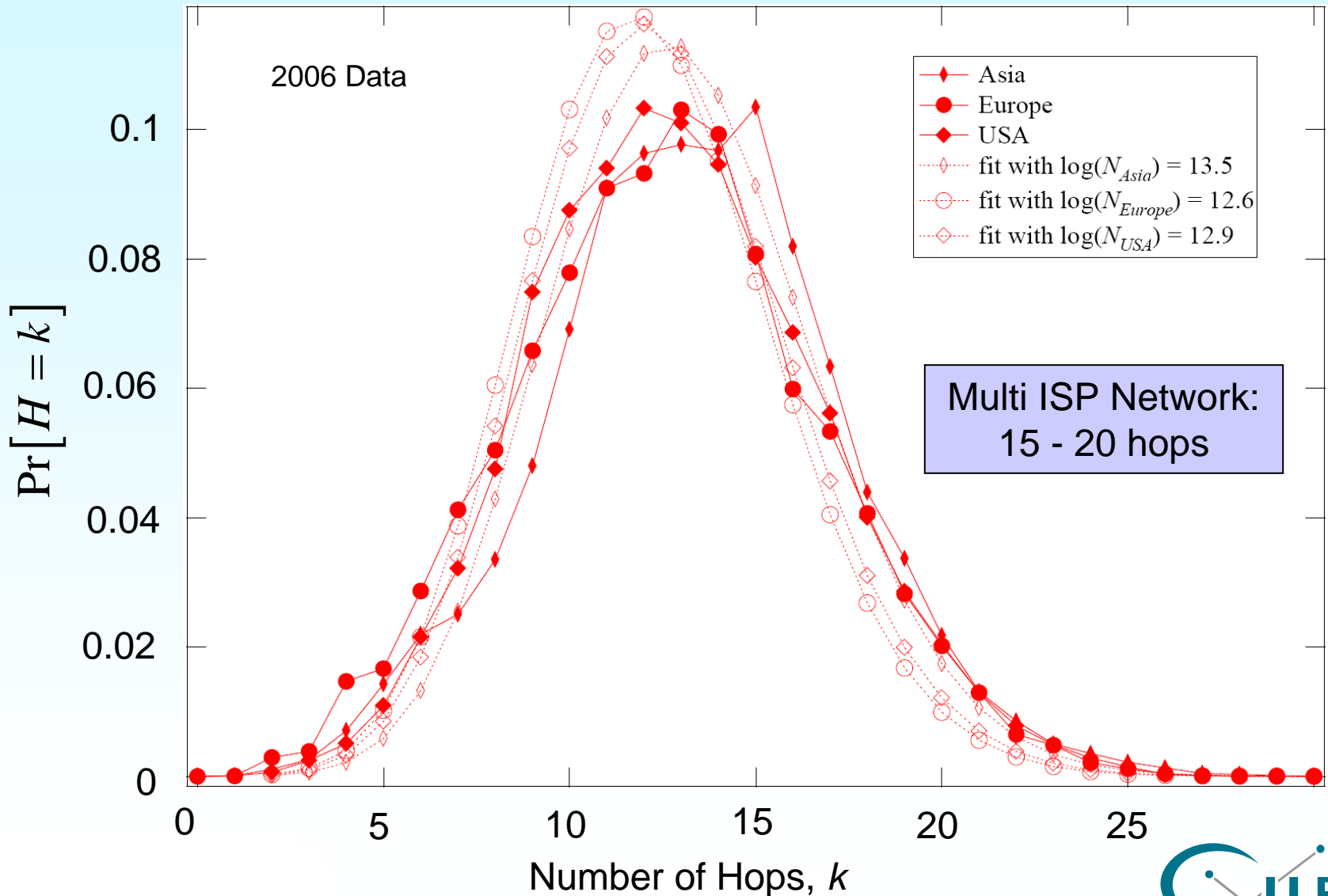

Source: P. Van Mieghem,
"Performance Analysis of Computer Systems and Networks", Cambridge (2006)

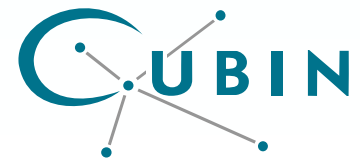

Power Consumption of IP Network

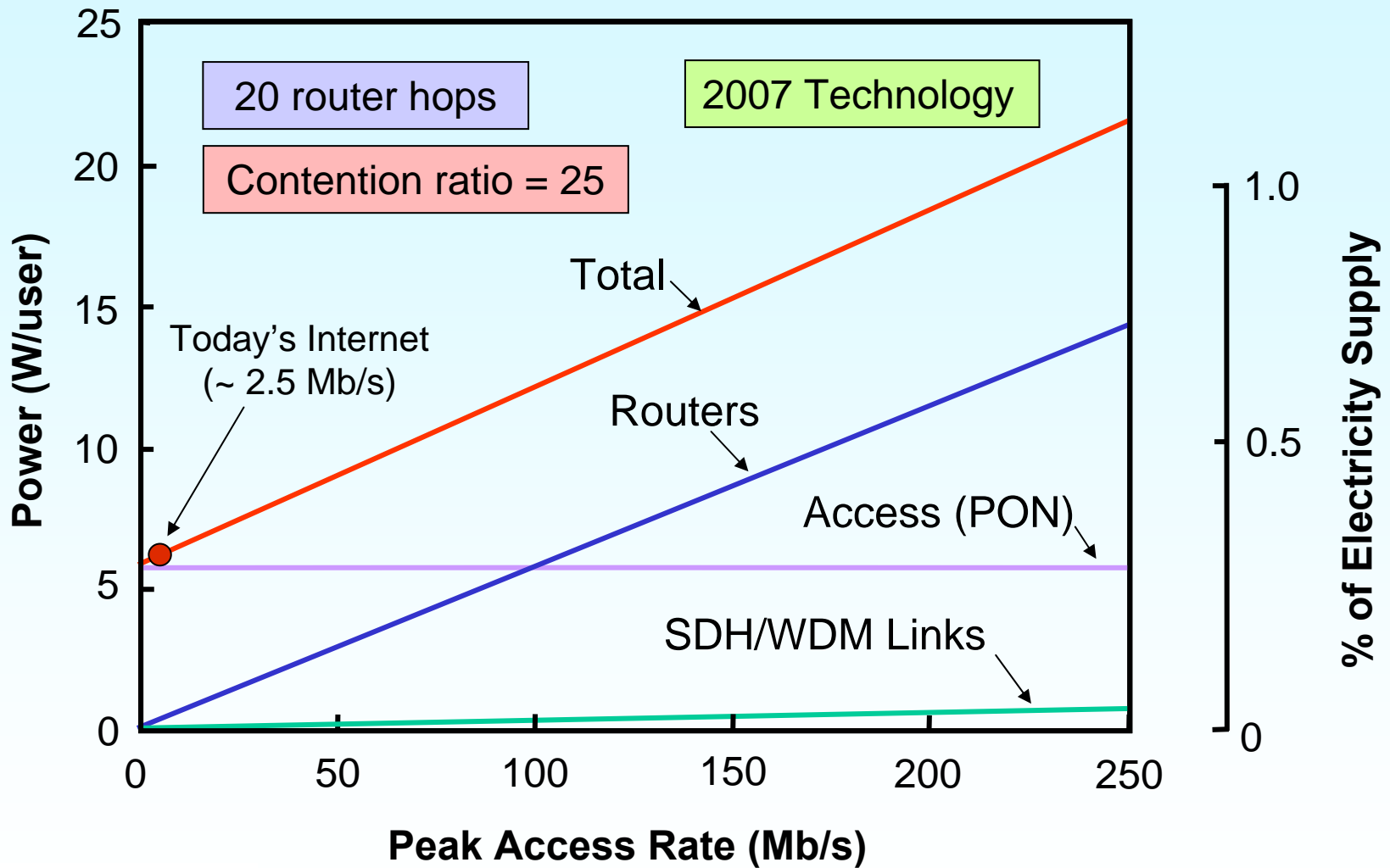

Ultra-Broadband Access

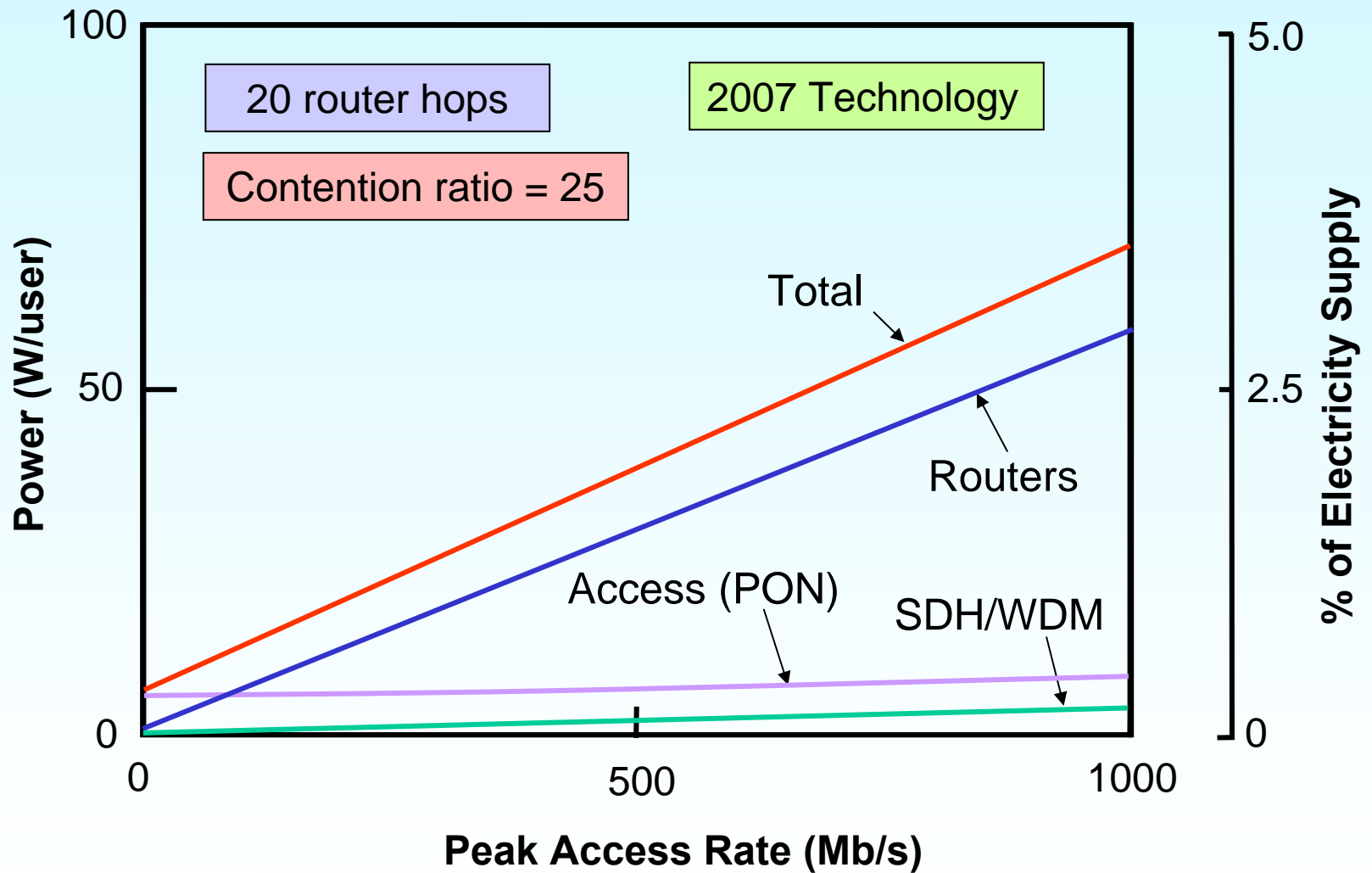

Energy Consumption in Access Networks

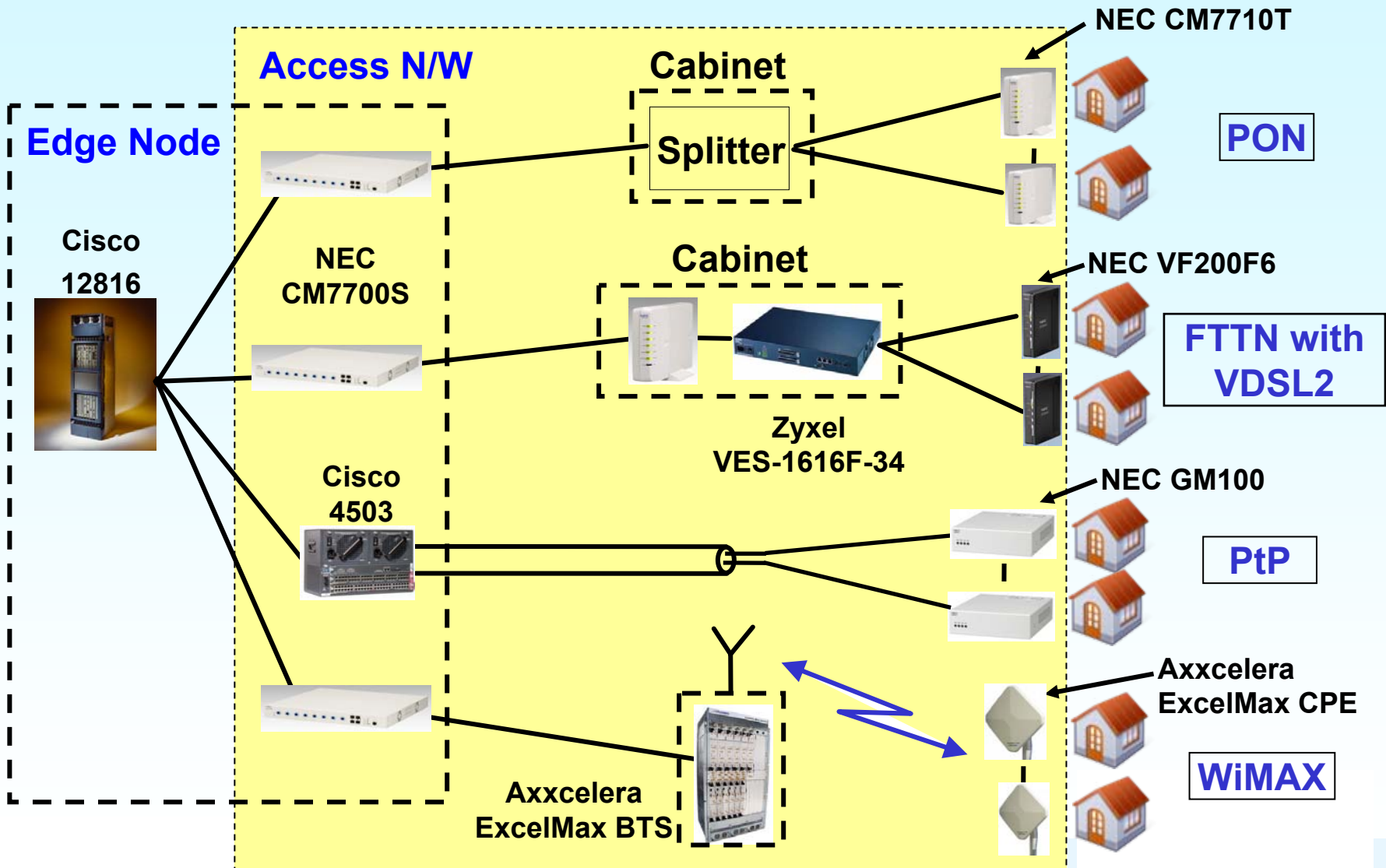

Power Consumption in Access Networks

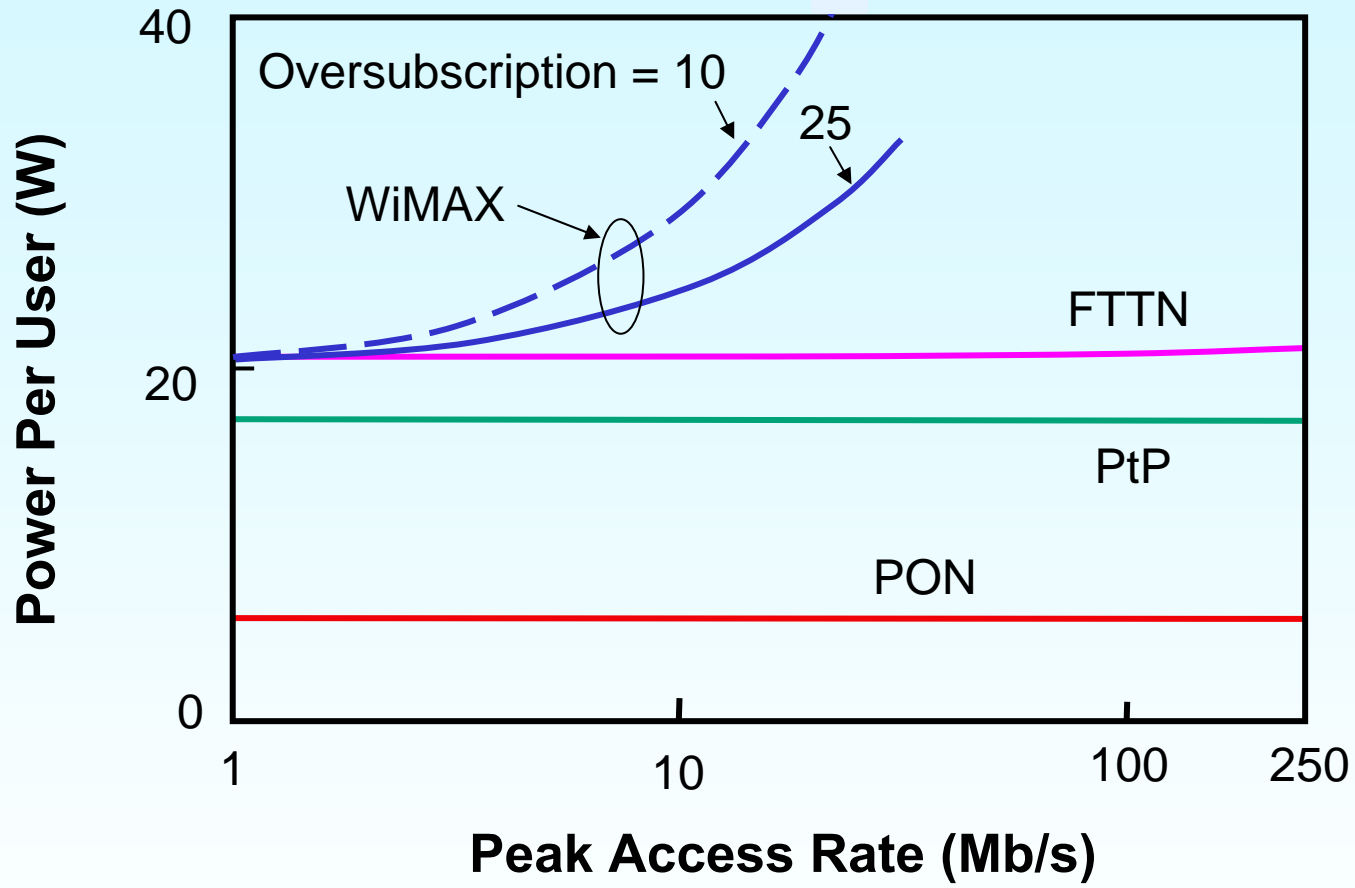

- Wireless access consumes more energy than optical access
- PON FTTH is “greener” than FTTN



Network Energy Consumption per Bit

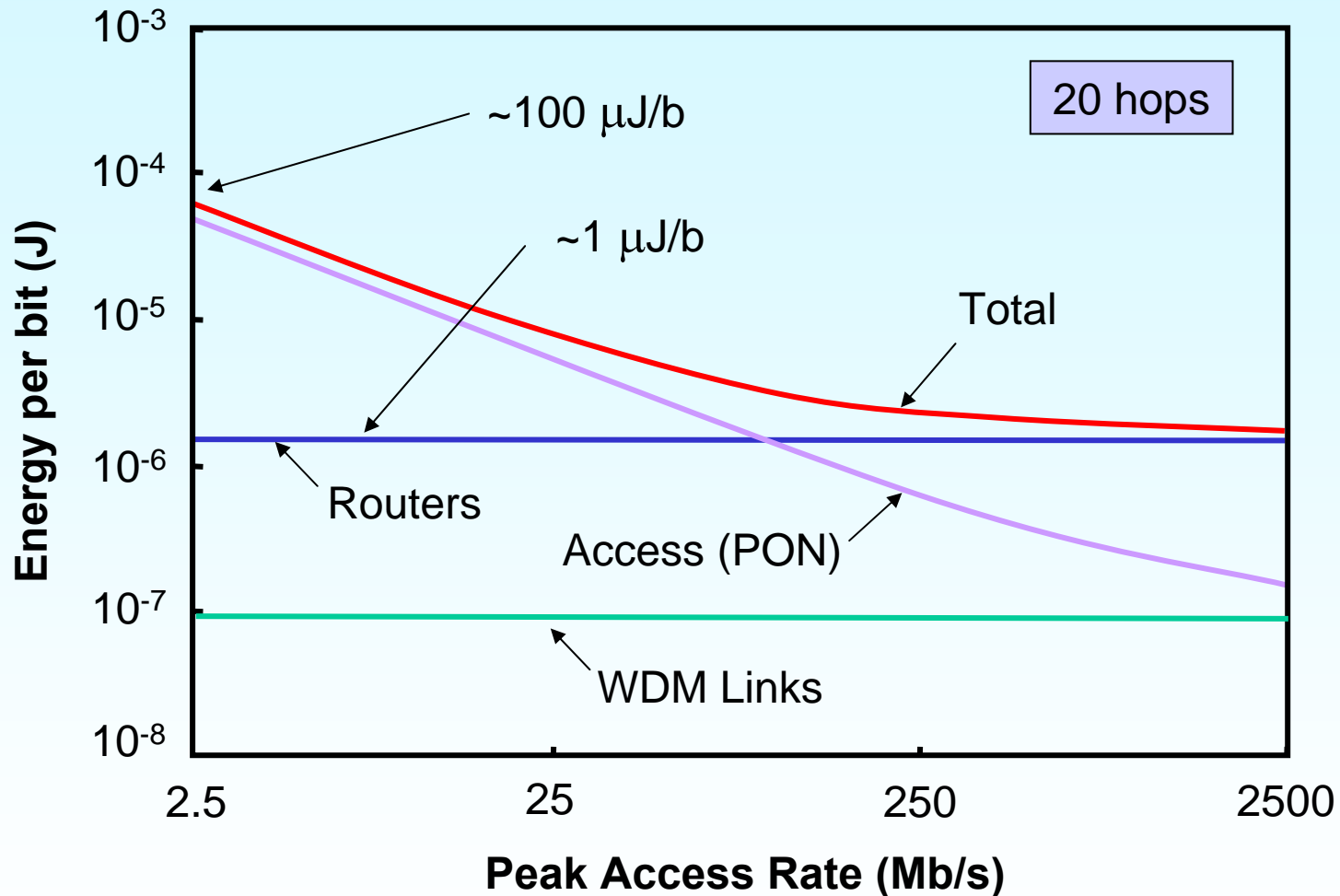

Observations

- Optical transport (WDM) consumes relatively little energy
 - < 5% of energy
 - > 25% of CAPEX
- Eliminating the O/E/O converters provides no significant benefit
- Access network dominates at low rates
 - Standby/Sleep mode is key to reducing energy consumption
- Network routers dominate at higher rates
 - Need to
 - **reduce hop count**
 - **improve router efficiency (technology)** ←
 - **manage routers better (sleep states)**
 - **develop better network architectures using fewer routers**
 - **manage distribution and replication of content (IPTV)**



Power Consumption in Routers

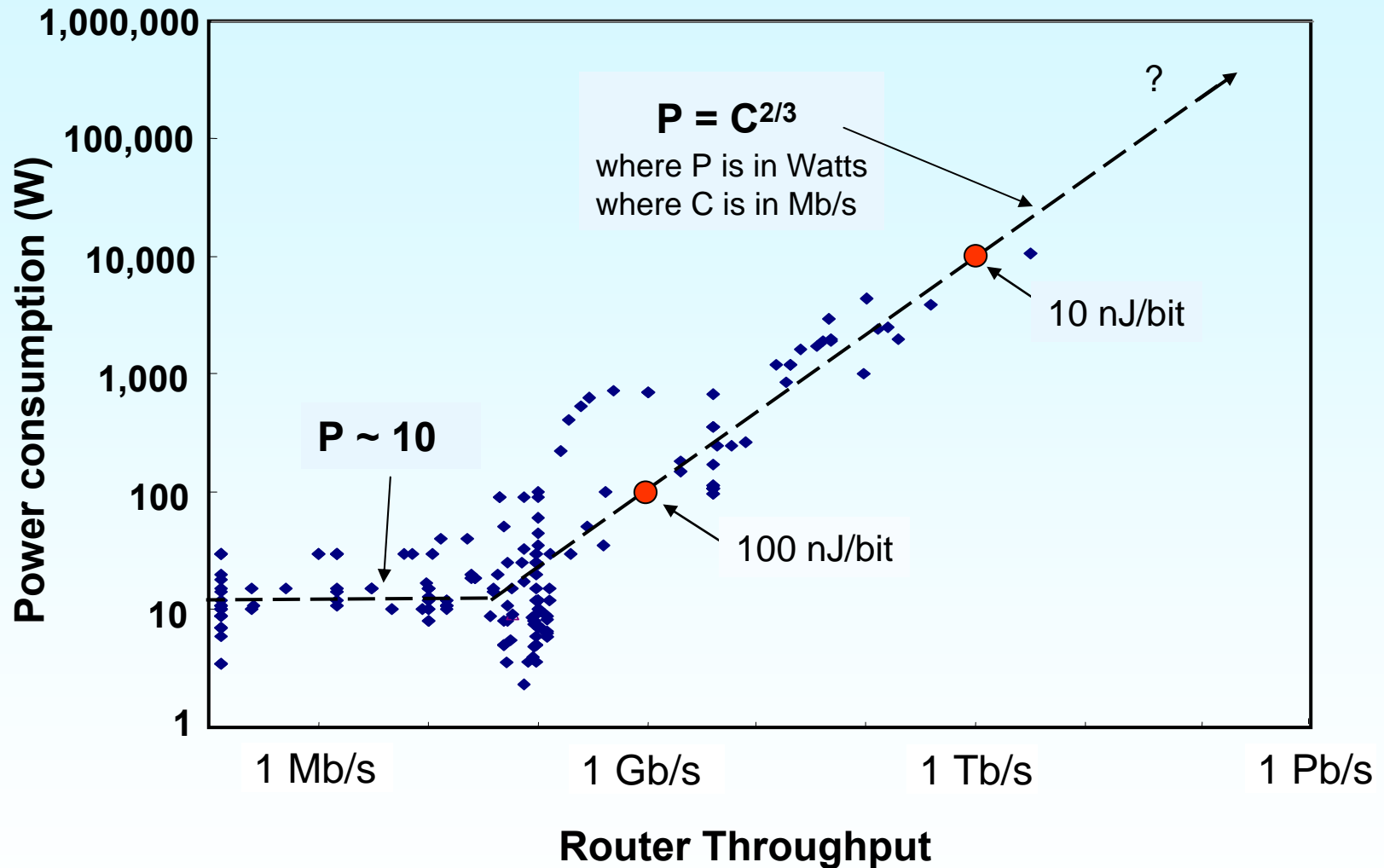

Energy Bottleneck

High-end router: Cisco CRS-1



Linecard Chassis
Capacity: 0.64 Tb/s
Power: 13.6 kW

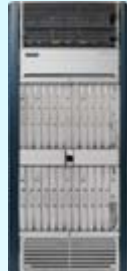

Switch Fabric Chassis:
Power: 8 kW

Fully equipped:
Multi-rack router
Capacity: 41 Tb/s
Power ~ 1 MW

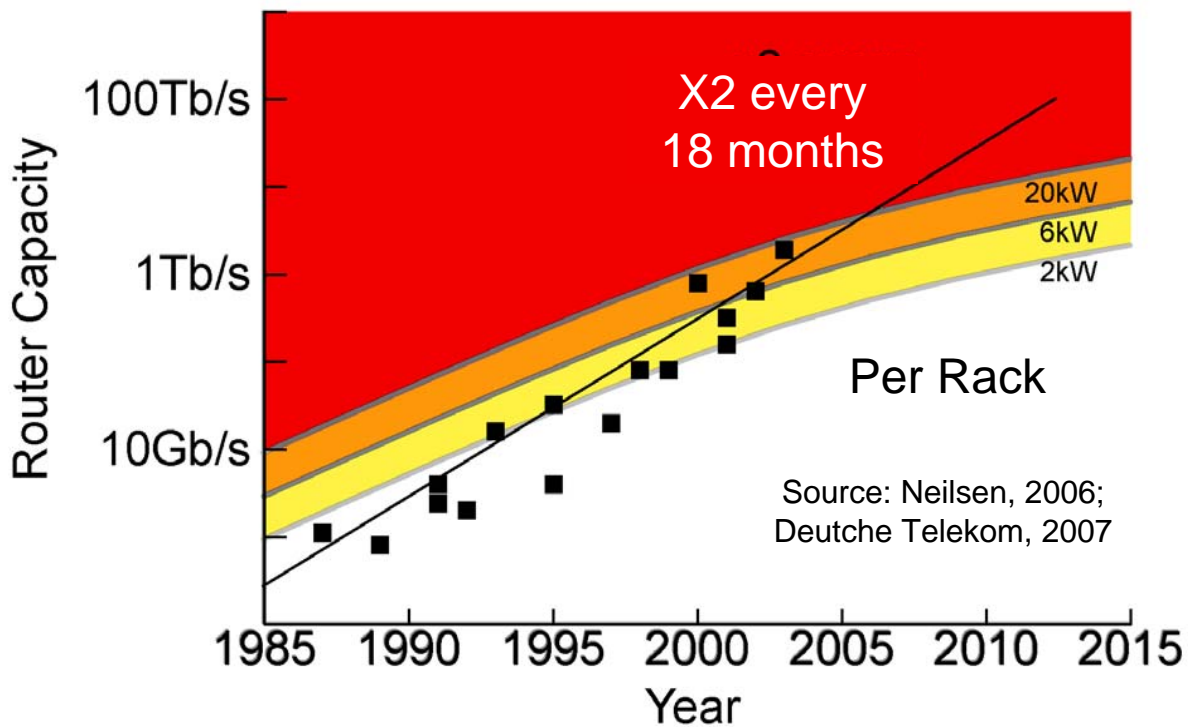

Electronic Routers

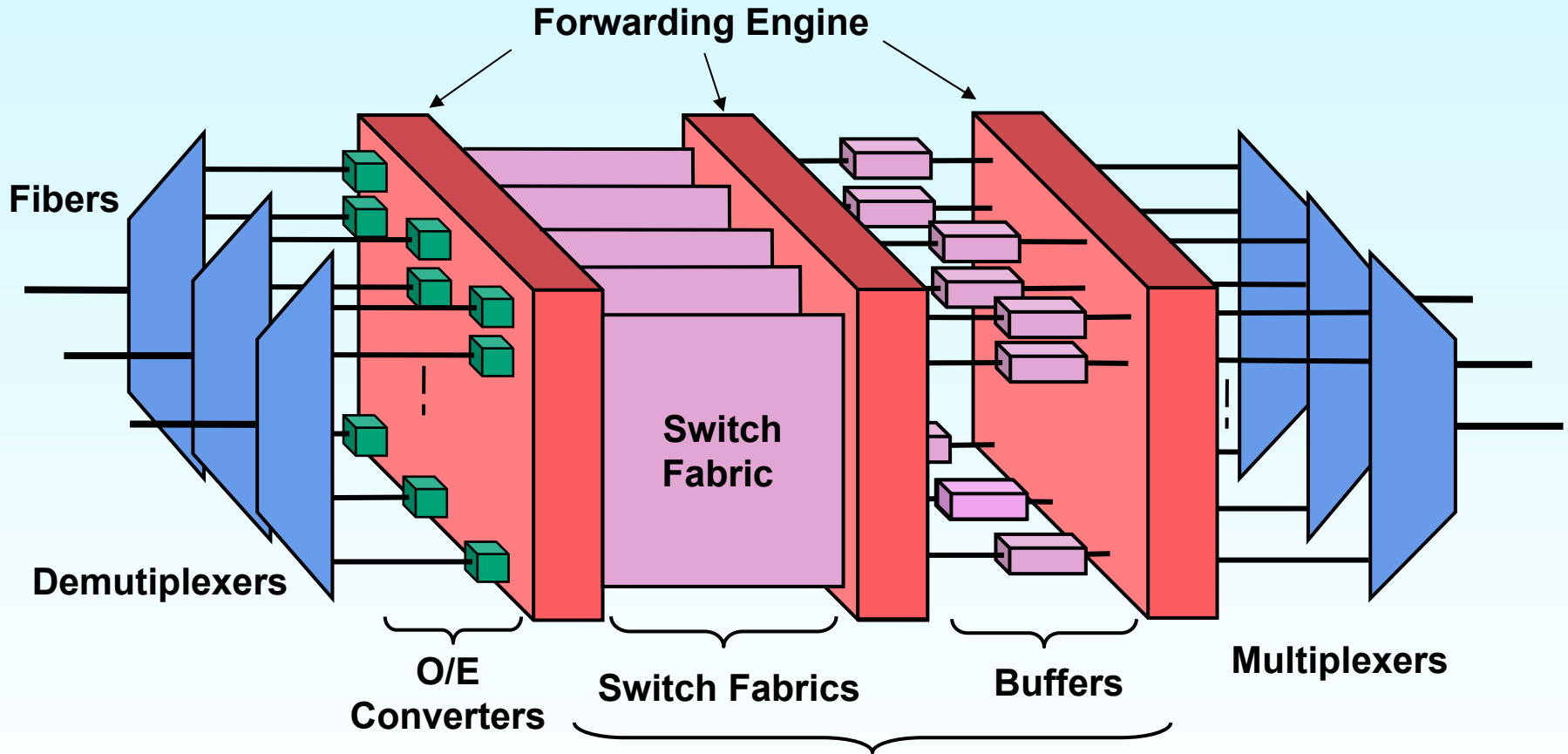

Reduced bit rate (i.e. parallel processing)

Speed (throughput) is not a limitation

Electronics

Optics



Energy in Electronic and Optical Routers

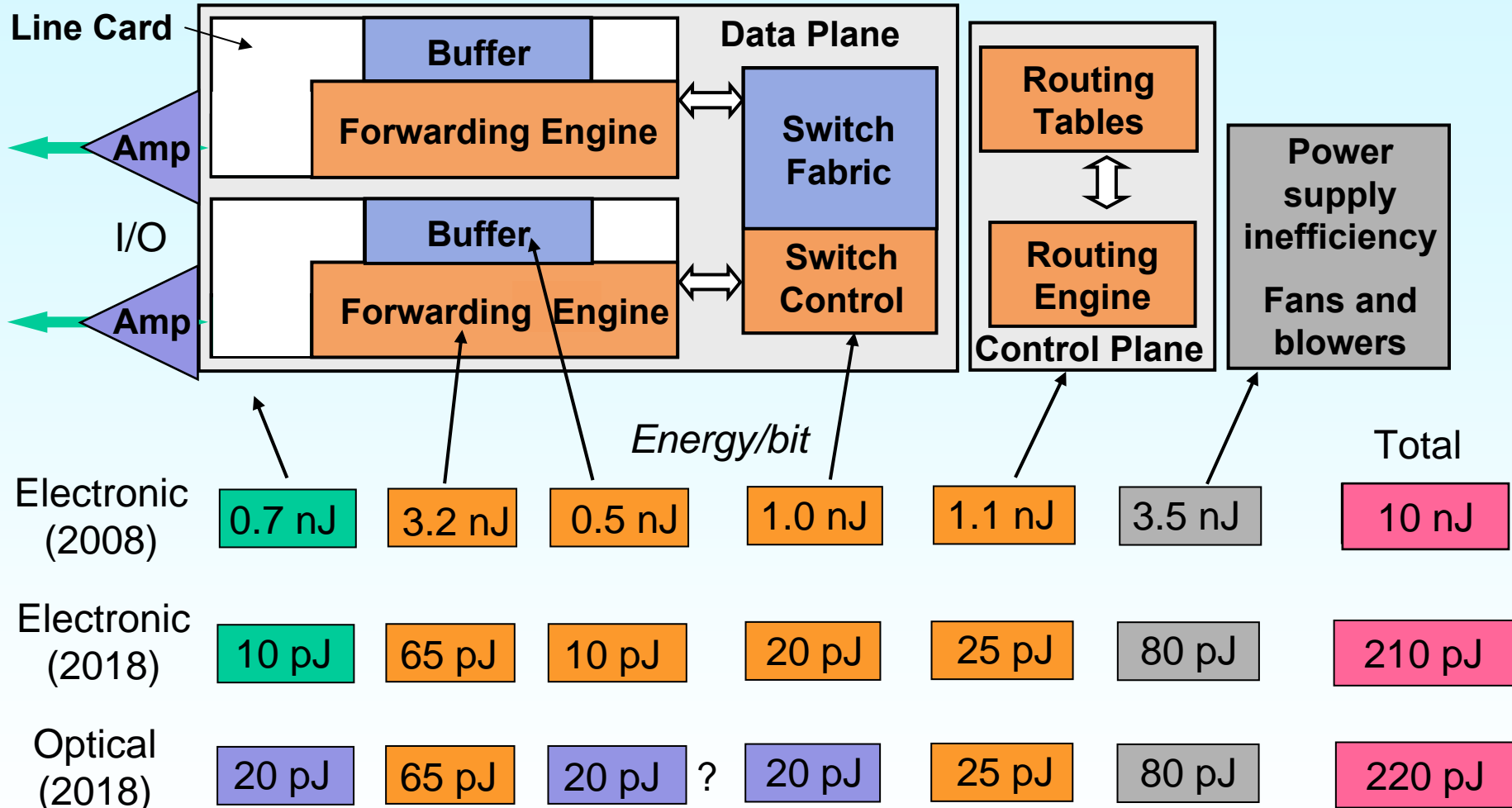

Optical Packet Switching is not a compelling alternative



Contention Resolution in the Wavelength Domain

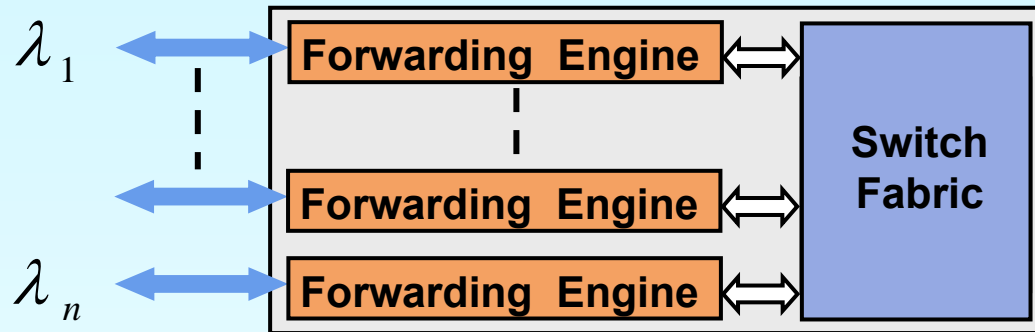

- Optical Burst Switch
- Optical Label Switch

Fatal Flaw: **Require large n** for low blocking probability ($n \sim 3 - 10 \times$)

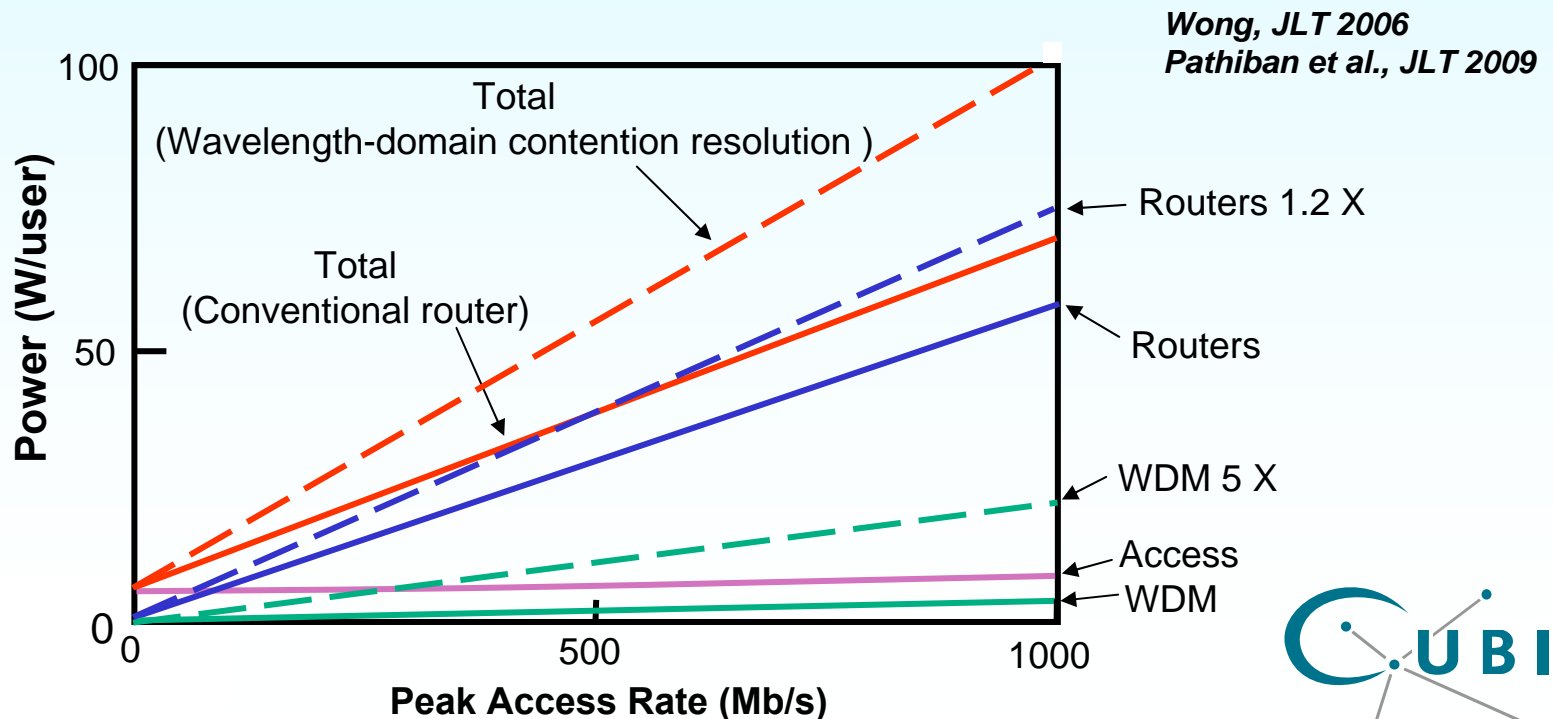

The Challenge

10 % - 20 % p.a. continuous improvement in efficiency

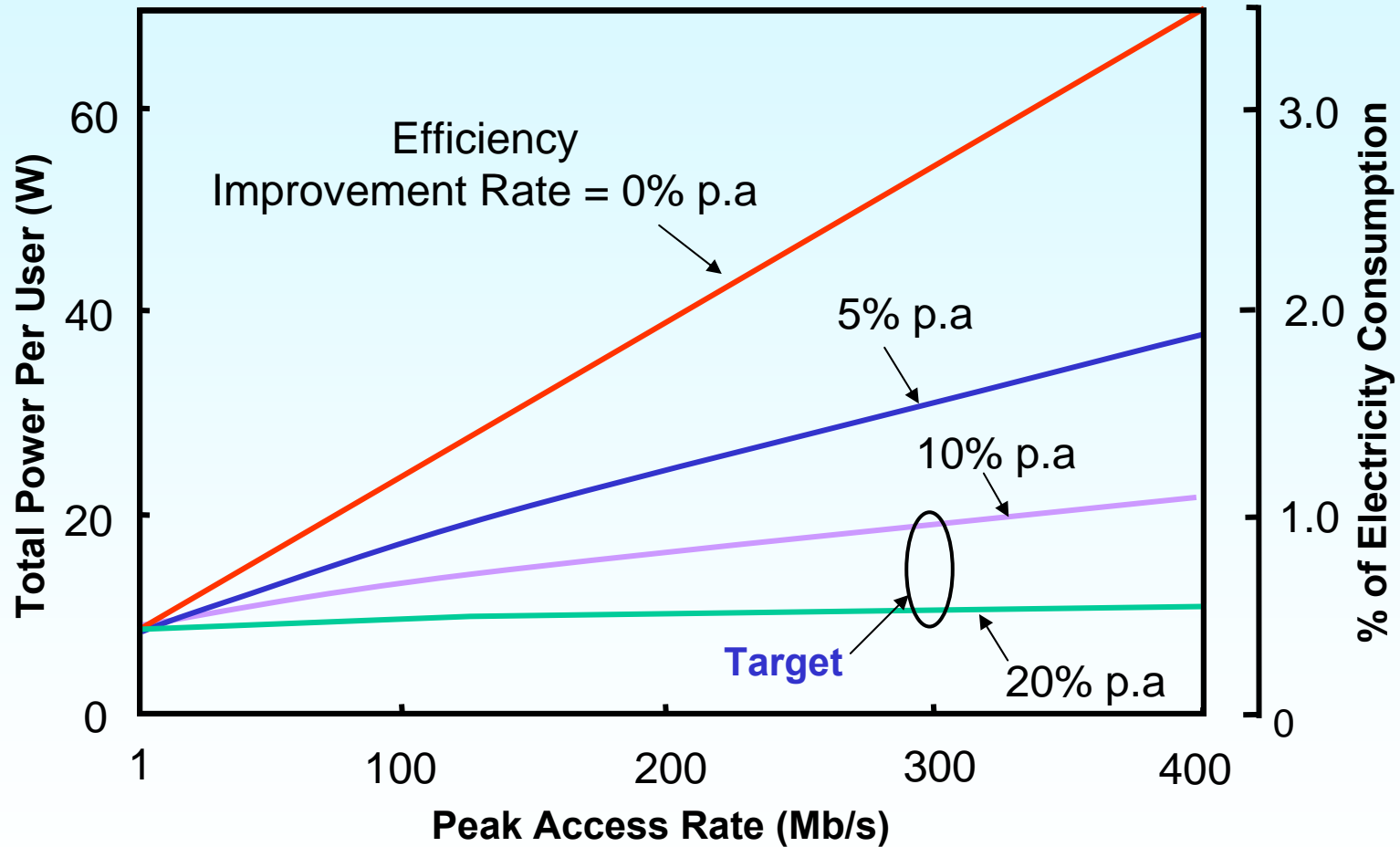

Summary

- Energy consumption currently dominated by the access network
- The energy bottleneck in routers is looming
 - More significant than the so-called “electronic speed bottleneck”
- Key strategies for efficient network design
 - Control energy in the access network (e.g. sleep mode in modems)
 - Reduce the hop count (i.e. “agile” optical bypass)
 - Energy-efficient network architectures
 - Continuous improvement in (electronic) router efficiency
 - Caching and content distribution networks
 - O/E/O conversions not necessarily a problem

